

SECURITECH GROUP, INC.

MP POLICE LOCK

Packing List

MODEL 4840B-TTBG_HG-3_ or 4840B-TTBG_HG-4_

Items:

Part#	Qty Name	Description/Usage	Part#	Qty Name	Description/Usage
	Lock Mechanism				
	1	4840 Mechanism	F15020800058603	4	Self-Drilling Screw
	1	Interior Cover	F0230102412631	4	Machine Screw (Phillips)
<input type="checkbox"/> HG	<input type="checkbox"/> BG	1	Guard Plate	<input type="checkbox"/> HardGuard	<input type="checkbox"/> BestGuard
	1	Turn Piece		1	Open T-nut (Threaded Cap)
				1	Allen Screw
					Standard shipped w/Rim Cylinder
					IC Core
					BEST compatible

Fasteners:

Part#	Qty Name	Description/Usage	Part#	Qty Name	Description/Usage
	Vertical Bolts				
	1	Upper Rod Assembly Including:		1	Bracket
		Channel	MB	1	Underplate
		Rod	MU(316)	4	Self-Drilling Hex Head Screws
		Round Deadbolt	M1	3	Locknut
	1	Lower Rod Assembly Including:	MB2	1	Bracket
		Channel	MB	1	Underplate
		Rod	MU(316)	4	Self-Drilling Hex Head Screws
		Round Deadbolt	M1	3	Locknut
			MB2		

Part#	Qty Name	Description/Usage	Part#	Qty Name	Description/Usage
	Horizontal Bolts				
	2	Horizontal Rod Assembly Including		2	Bracket
		Channel	MB	2	Underplate
		Rod	MU(316)	8	Self-Drilling Hex Head Screws
		Round Deadbolt	M1	6	Locknut
			MB2		

Part#	Qty Name	Description/Usage	Part#	Qty Name	Description/Usage
	Strikes				
Q	1	Floor Sleeve			

Documentation:

PKG4840out: TTHG/BG-37 INS4840B-TTBG_HG-37 Tmp Grout TMP48	Packing List: 4840B-TTHG/BG-37 Instructions: 4840 Outswinging Grout box 4840 Template
---	--

MP POLICE LOCK™**OUTSWING DOOR**

Installation Instructions

Model # 4840B-TTBG_HG

Questions?

406-212-2334**PLEASE REVIEW PARTS &
INSTRUCTIONS
BEFORE INSTALLING**

MP 4840B

Out-Swing Round Bolt

Parts View

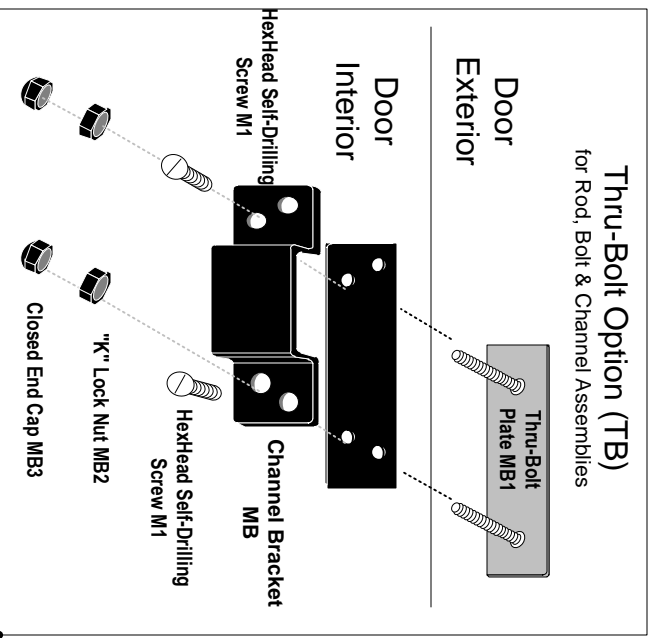
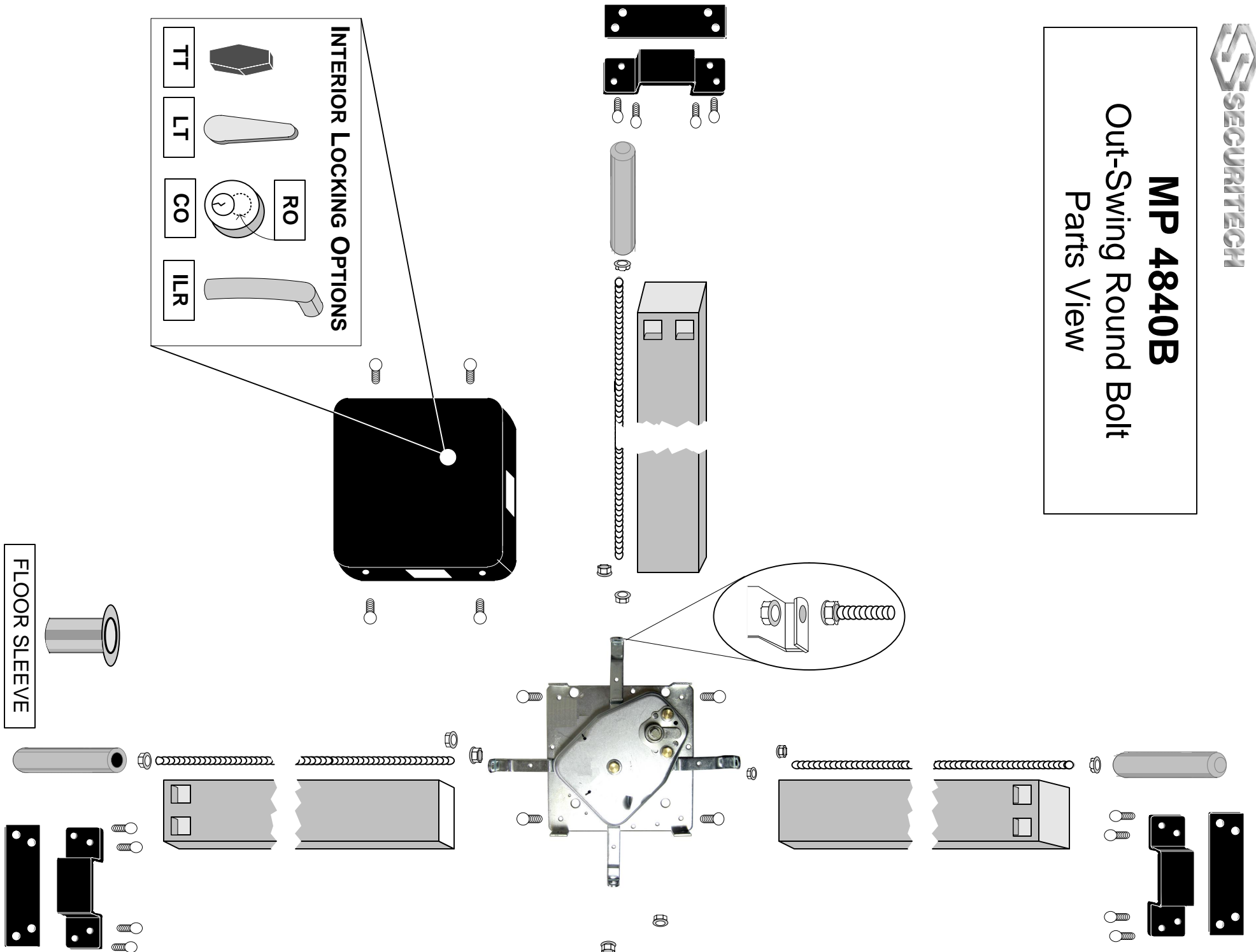

replaces standard Shim, Bracket & 4 Screws

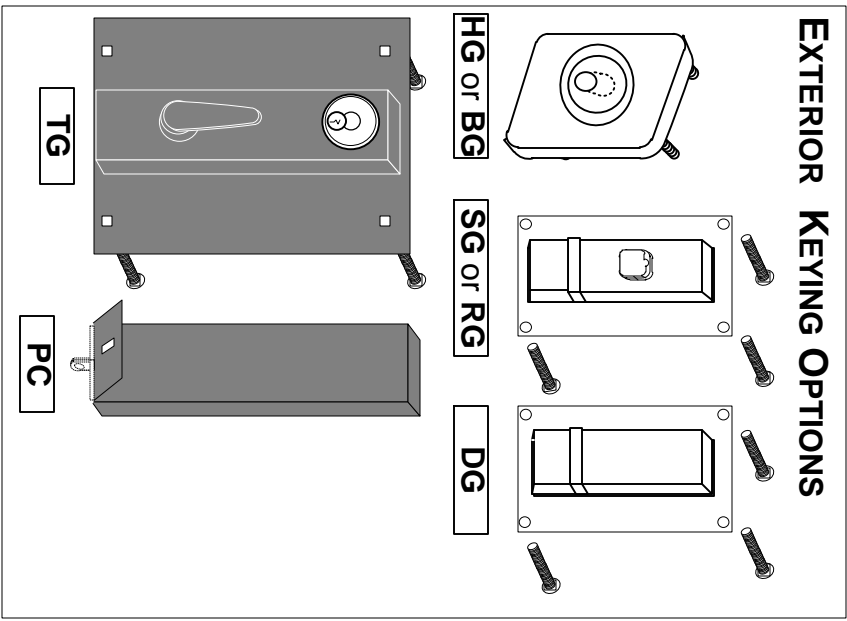
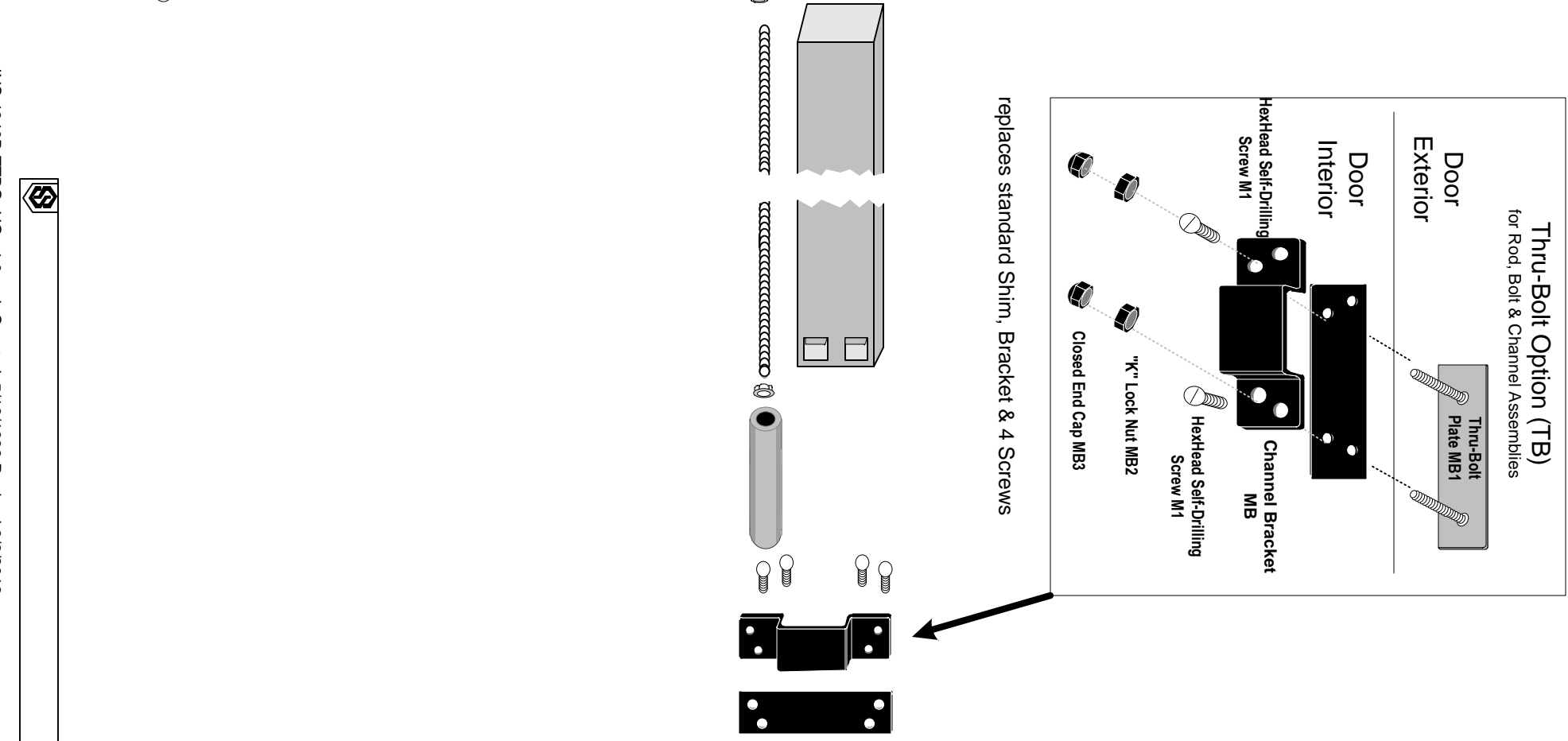

OUTSWINGING DOOR

The following steps are designed for #4800 for a 3'X7' door. If you have a smaller size door and need to cut the channels & rods. Please measure carefully and cut evenly!

1) MARKING & DRILLING Determine the handing of the door you are installing this device on. Use the correct side of the template to mark your holes.

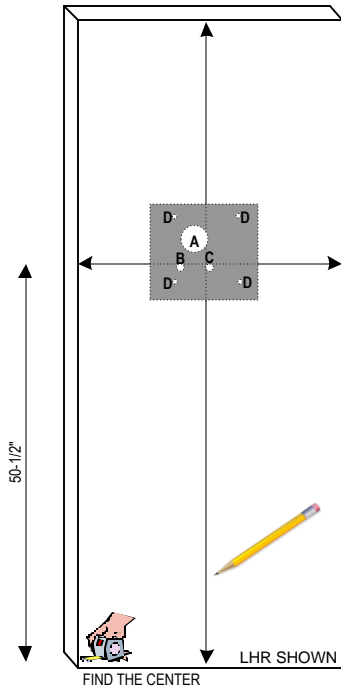

1) On the inside face of the door, mark a cross at a height of 50-1/2" and at the center horizontally. **Extend the lines to all the edges of the door making sure the lines are straight!**

MARK THE HOLES

1) Line the mechanism template up with the marks made and use masking tape to secure the template to the door. Center punch all the holes.
2) Use the **4800 Thru-bolt bracket template** to mark the holes NOW.

DRILL HOLES- MAKE SURE DRILL IS LEVEL AT ALL TIMES

USING TMP4800 TEMPLATE (SEE HOLE SCHEDULE):

1) Drill holes "D" 1/8" on **INTERIOR ONLY**
2) Drill hole "A" (2-1/8" thru the door).
3) Drill holes B & C (1/2" thru the door).

USING 4800 THRU-BOLT BRACKET TEMPLATE (OPTIONAL):

1) Drill holes 5/16"
2) Remove all burrs and remove any debris in the holes from insulation etc...

CARD BOARD TEMPLATE PROVIDED

A

B

C

HOLE	SIZE
A	2-1/8"
B	1/2"
C	1/2"
D	1/8"

4800 SERIES WITH

NO OUTSIDE KEY CONTROL (XX) A, C, D NONE

OUTSIDE KEY CONTROL (HG&BG) A, B, C, D A, B, C

OUTSIDE KEY CONTROL (SG&RG) A, B, C, D A, B, C

TMP000035-01 v1.0

CARD BOARD 4800 THRU-BOLT BRACKET TEMPLATE

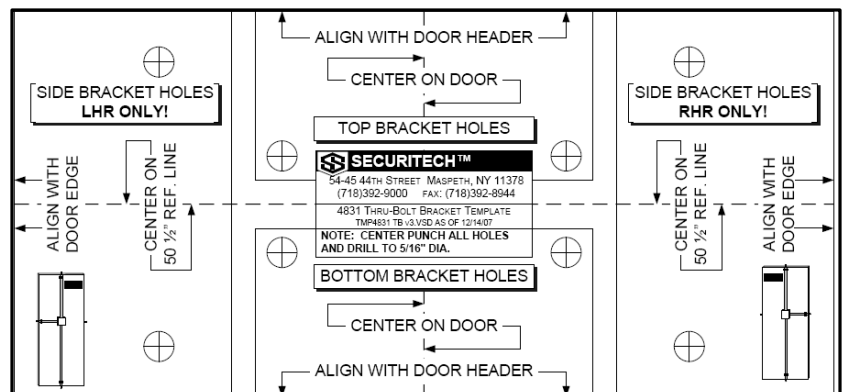

IMPORTANT: DO NOT USE CYLINDERS GREATER THAN 1-3/8" LONG (FOR 1-3/4" THICK DOOR)

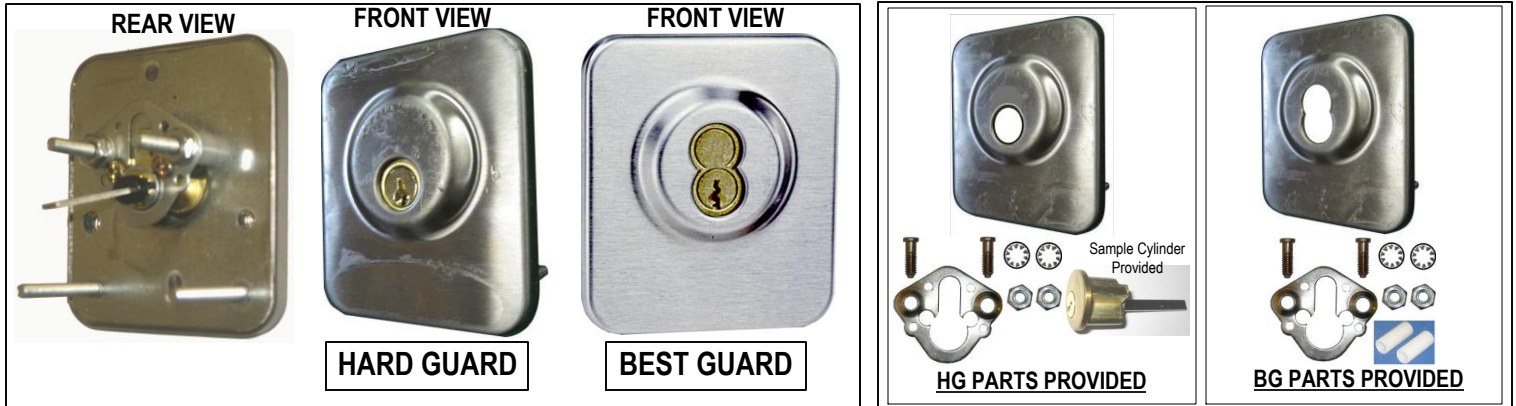

CYLINDER INSTALLATION TO THE EXTERIOR GUARD PLATE :

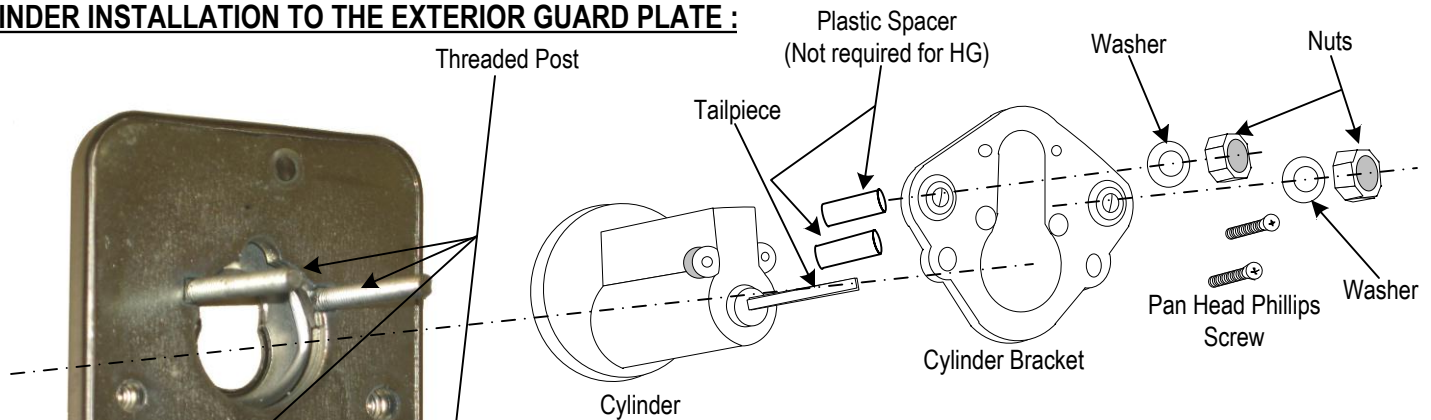

Exterior Hard Guard / Best Guard

NOTE:

1) A sample cylinder is shipped mounted in the guard plate. To install a high security or RC cylinder, remove the nuts and fastening screws.

A sample cylinder should be replaced with a high security or RC cylinder.

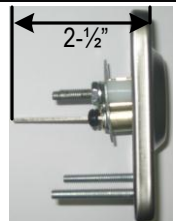

2) Make sure the tailpiece is long enough extend into the lock mechanism. If it is too short, replace with the tailpiece furnished on the cylinder originally mounted in the guard plate.

- 1) Insert cylinder into exterior HG/BG guard plate.
- 2) **A** Line up the cylinder bracket holes with the threaded post of the exterior guard plate. Insert cylinder bracket over the rim cylinder.
- 3) **B** Make sure the cylinder tail piece is straight (horizontal or vertical) and then fasten the washers and nuts. Do not over tighten the nuts, adjust until the rim cylinder is properly seated.
- 4) **C** Line up the pan head Phillips screws with the threaded holes and tighten them with the help of screw driver.

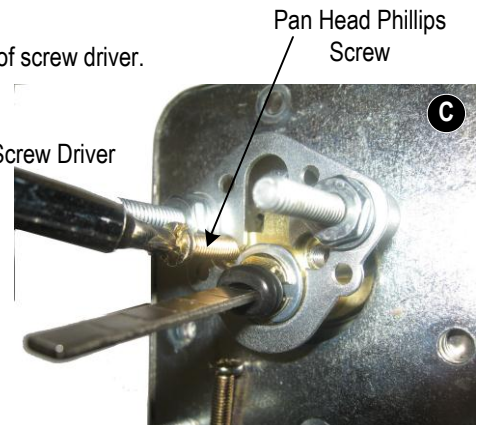
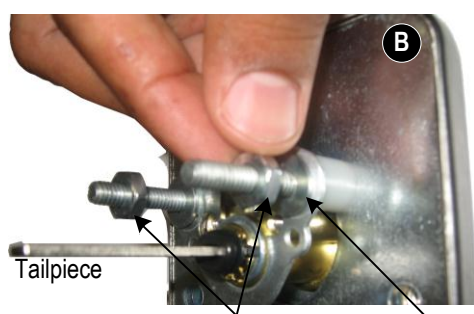
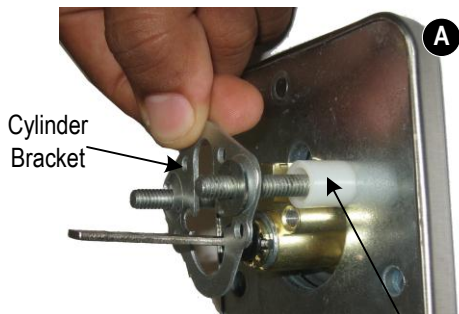

Plastic Spacer (Not required for HG)

2) INSTALL MECHANISM & GUARD PLATE

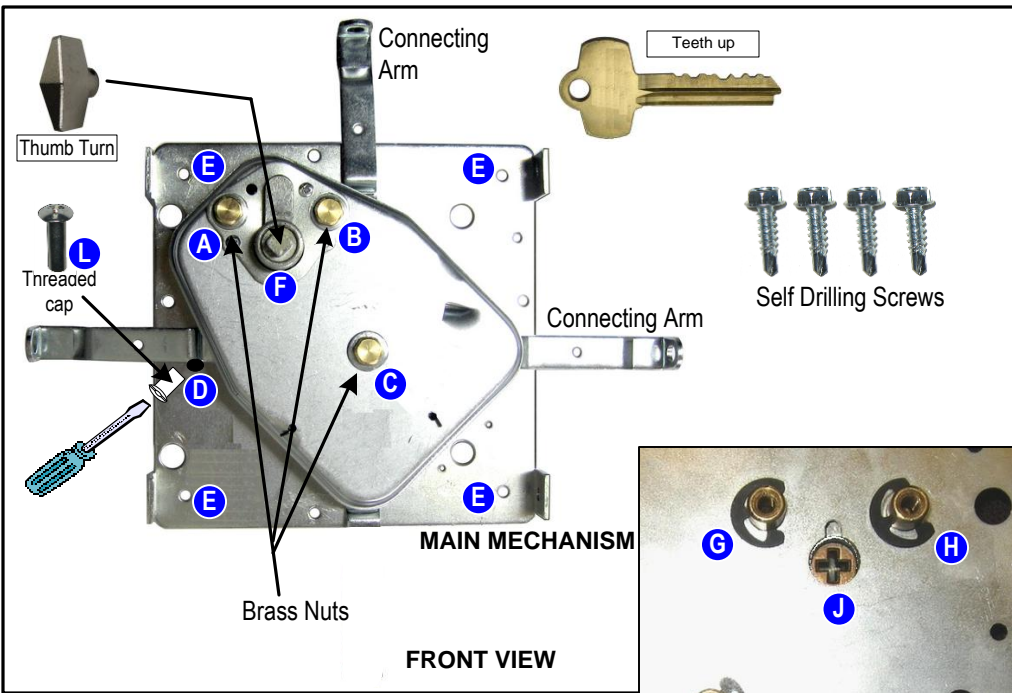

MECHANISM – REMOVE THE 4 SCREWS AND COVER. RETAIN THE SCREWS FOR INSTALLATION LATER.

1) Line up the **E** holes with the 1/8" hole made using TMP4800 cardboard template. Fasten the mechanism to the door with the (4) self drilling screws.

2) Place the thumb turn on the post **F** and turn a few times to test the mechanism. Retract the connecting arms before moving to the next step. From the outside of the door, use a screwdriver to ensure that the cross hair **J** inside the mechanism appears like picture below.

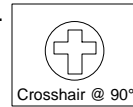

EXTERIOR GUARD PLATE- INSTALL THE CONSTRUCTION CORE BEFORE TESTING THE MECHANISM

1) Make sure the cylinder tailpiece is straight (horizontal). Use a flathead screwdriver to lift the tailpiece into the crosshair **J**.

2) Line-up the 4 guard plate posts **K** with the brass bushings **G**, **H**, **I** and the hole **D**. You may need to wiggle the guard plate to line up all the posts.

3) Use a 3/8" nut driver to attach each post to the brass nut **C** first. Turn a few times then repeat for all nuts **A** & **B** until exterior guard plate is secured to mechanism and flush with the door. Alternate tightening the posts to seat the plate properly.

4) Finally, use a flathead screwdriver to tighten the threaded cap **L** to the post in hole **D**. Make sure all are tight.

5) Test for smooth operation.

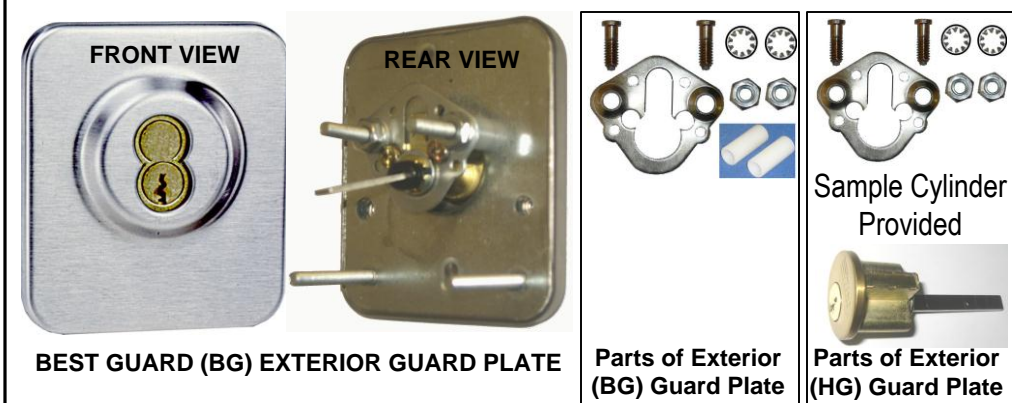
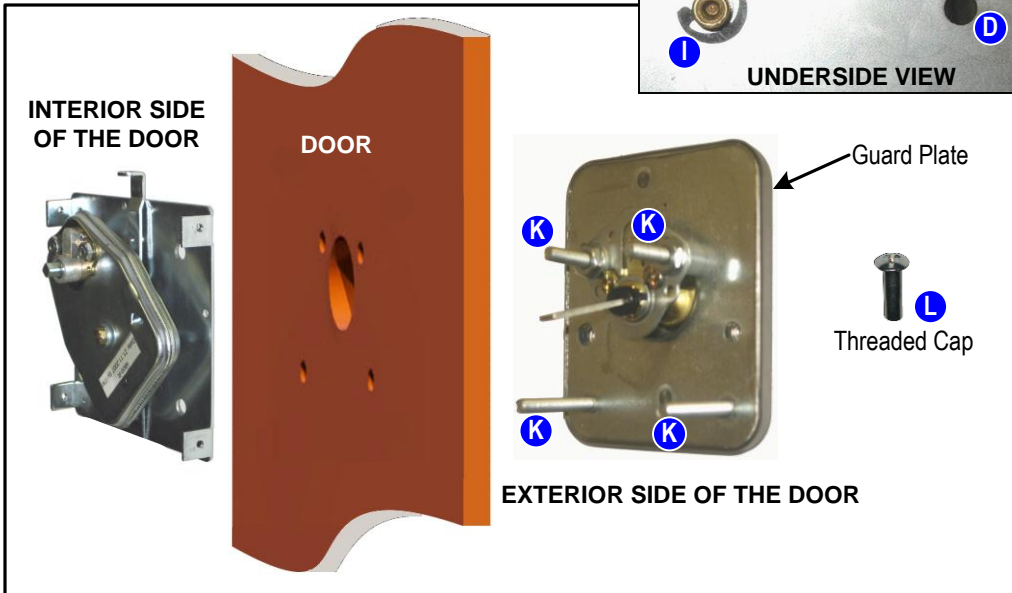

The M.P. is shipped so that the interior lock will be centered on the door. The exterior guard plate will be 1" off-center.

3) INSTALL VERTICAL AND HORIZONTAL DEADBOLTS

Make sure the rod holders are in the retracted (shorter) position.

Install the bottom rod first! The 48" long rod in the box.

1) **A** Remove the tape from the rod and channel. Do not remove the rod from the channel. Place the **channel** vertically on the door so that the end of the channel just clears the bottom of the door.

2) **B** Holes are already drilled for the brackets. Place the bracket over the channel first then place an under-plate underneath the channel and align with bracket.

(Under-plates are used to ensure that the bolt clears the frame or frame stop. Extra shims are provided if needed.)

3) **C** Adjust the height of the rod by adjusting the location of the threaded rod by sandwiching the tip of rod holder between the top and bottom nuts. **MAKE SURE THE NUTS ARE TIGHT!!!** The top of the **channel** can be held against the mechanism and the bottom of the channel should be flush with the bottom of the door edge.

4) **D** Finally, secure the bracket with (4) #14 hex-head self-drilling screws. Make sure the bolt travels through the guides in the bottom of the channel. **MAKE SURE CHANNEL IS LEVEL!!!**

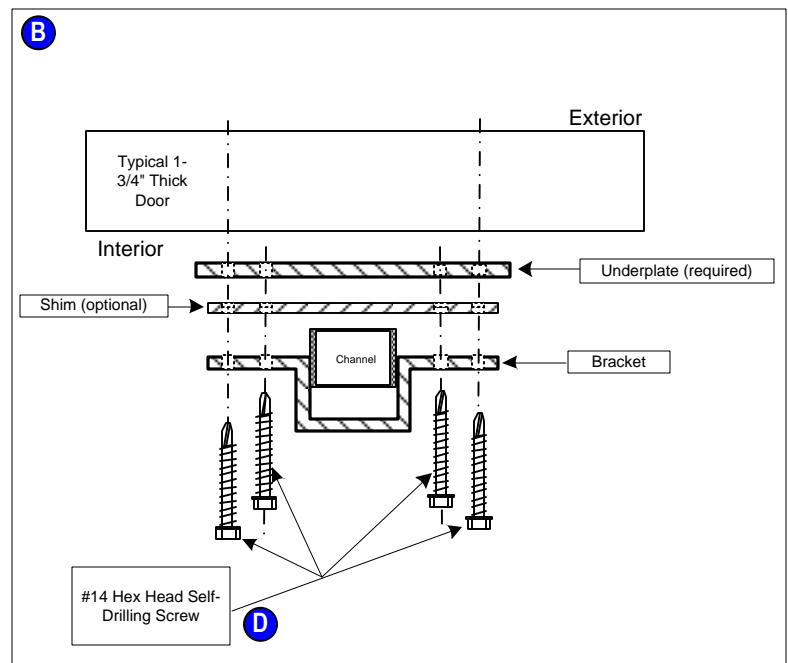
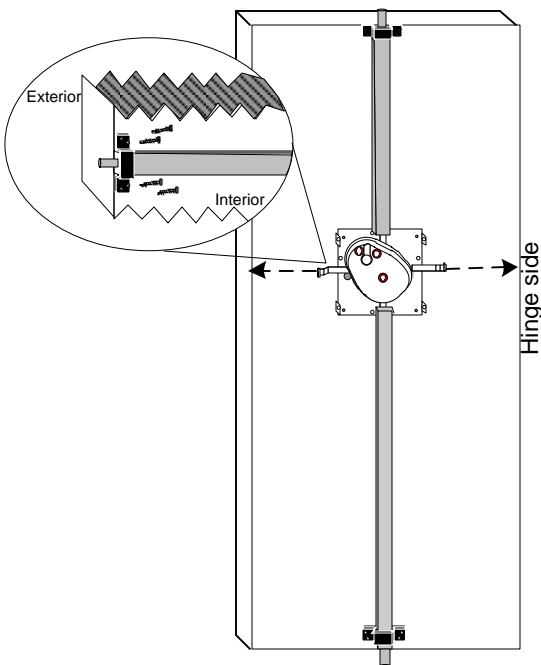
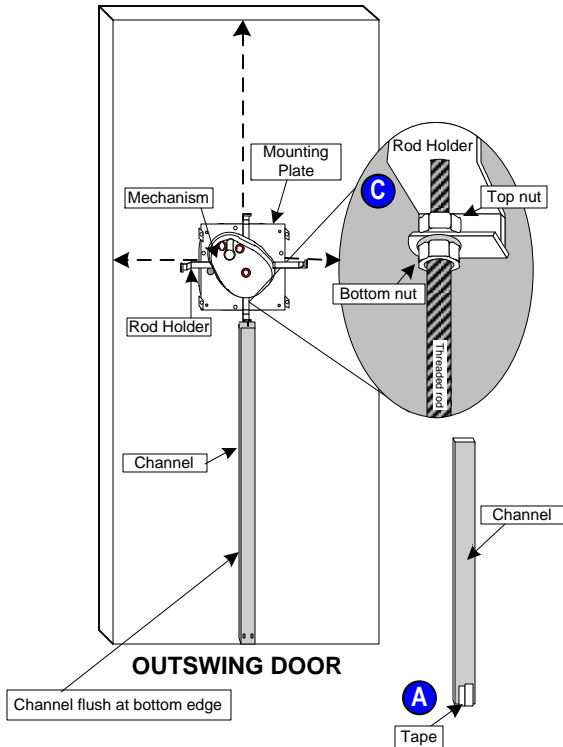

5) Repeat all steps for the top and horizontal bolts. Note: These bolts will be round and project into the frame. See page 3.

For Horizontal Bolts : Adjust until the bolt is approximately 1/8" from the door stop.

4) INSTALL DUST PROOF STRIKE (FLOOR)

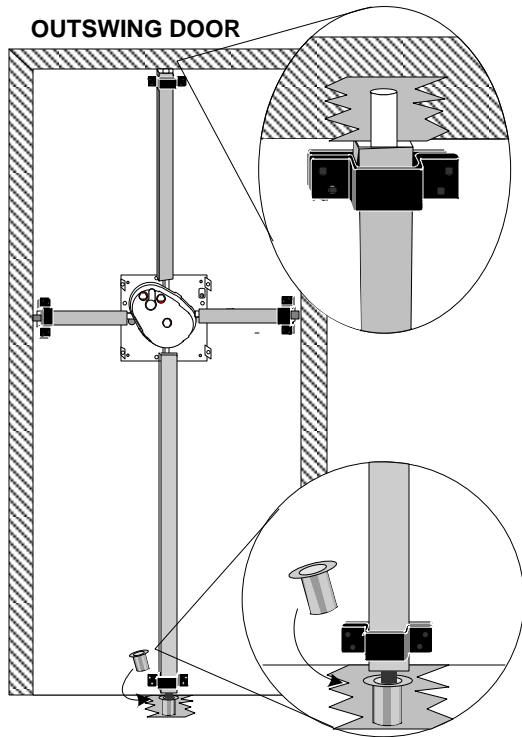

Drill holes for round bolts: Into Floor/Saddle & Frame

- 1) Close the door (If free swinging, place some paper under the door to hold closed). Place a little putty on the tip of the bolts. Turn the thumb turn piece until the bolts hit the saddle (or floor) and frame then retract.
- 2) Open the door.
- 3) Using the center of the marks, drill 1/8" pilot holes up to a 3/4" dia. holes.
- 4) For the bottom bolt, drill up to an 1" & 3" depth hole and insert the floor sleeve using some kind of epoxy to keep in place.

5) INSTALL MECHANISM COVER

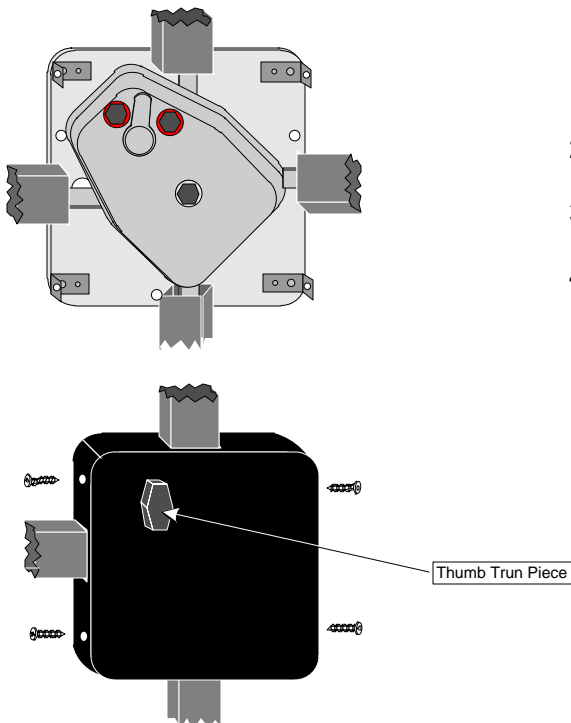

- 1) Place the cover over the mounting plate and channels.
- 2) Check for smooth operation by using the thumb turn piece.
- 3) Fasten the cover with four phillips screws.
- 4) Fasten the thumb turn piece with the 1/16" allen key provided.

1/16" Allen Key

Thumb Trun Piece